



**THIS TOOL IS FOR USE ONLY BY LICENSED OPERATORS. YOU MUST OBTAIN A LICENSE BEFORE USING IT. A TOOL OPERATOR'S CARD WILL BE ISSUED TO YOU AFTER SUCCESSFULLY COMPLETING THE ENCLOSED EXAM AND RETURNING IT TO RECEIVE YOUR CARD AND ACTIVATE YOUR WARRANTY.**

***DUO-FAST***  
**CONSTRUCTION**

# ***TriggerDrive***

**LOW VELOCITY POWDER ACTUATED TOOL**

## **Operator's Instruction & Training Manual**



- *The Duo-Fast TriggerDrive is a light duty tool designed for applications such as small room additions and basement remodels. Tool life will vary depending on work site conditions and application.*
- *The TriggerDrive is a low velocity piston type fastening tool. It is designed for use with Duo-Fast .22 caliber powder loads and Duo-Fast fasteners.*
- *Do not operate the TriggerDrive before studying this manual carefully and thoroughly understanding the material contained herein.*

**IMPORTANT:** *The tool warranty is only activated upon receipt by ITW Brands of the completed Operator's Exam.*

# WARRANTY

ALL WARRANTIES OF THE PRODUCTS DESCRIBED HEREIN, EXPRESSED OR IMPLIED, INCLUDING THE WARRANTY OF MERCHANTABILITY AND FITNESS FOR PARTICULAR PURPOSES ARE SPECIFICALLY EXCLUDED, EXCEPT FOR THE FOLLOWING: ITW BRANDS WILL REPAIR OR REPLACE AT ITS SOLE OPTION ANY TOOL PART OR FASTENER WHICH WITHIN 90 DAYS AFTER SALE BY ITW BRANDS IS FOUND BY ITW BRANDS TO BE DEFECTIVE IN MATERIAL OR WORKMANSHIP, NORMAL WEAR AND TEAR EXCLUDED. THIS IS THE SOLE WARRANTY OF ITW BRANDS AND THE SOLE REMEDY AVAILABLE TO THE BUYER.

For warranty returns contact: ITW Brands, Attn: QA Department,  
1575 Hunter Road, Suite A, Hanover Park, IL 60133; Phone: (877) 489-2726.

---

**NOTE: It is very important that the operator of this tool completely reads and understands the entire tool manual and completes the Operator's Exam on the last page. The warranty will not be valid until the test is received, along with a copy of your sales receipt, and reviewed by ITW Brands.**

---

## TO AVOID SERIOUS INJURY OR DEATH

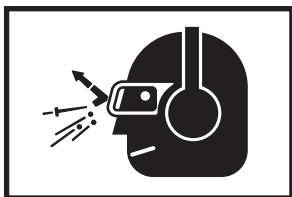

**Operators and bystanders must wear eye and hearing protection.**

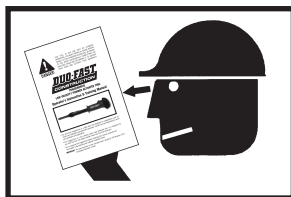

**Read manual before operating tool.**

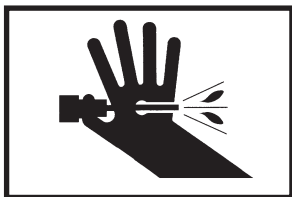

**Never close tool with hand over fastener loading end of the tool.  
A serious hand injury from penetration by the piston or a discharged fastener could result.**

---

# WARRANTY

# SAFETY PRECAUTIONS

**IMPORTANT:** In order to activate your warranty, you must read this manual thoroughly, complete the exam and return to the address on the back page of this manual.

**WARNING!** The following pages contain detailed warnings, cautions, and rules of safe operation with which the operator must be familiar and follow to avoid serious injury or death. After thoroughly reviewing this manual, complete the Operator's Exam and return to ITW Brands for your Operator's Card and to activate your warranty.

## BEFORE LOADING AND FIRING PROTECT YOURSELF AND OTHERS

1. Never place your hand or fingers over the front muzzle of the tool - the fastener or piston can seriously injure your hand in the event of an accidental discharge.
2. Always use only Duo-Fast fasteners and loads at all times for consistent tool functioning.
3. Operators and bystanders must wear eye and hearing protection at all times. Serious eye injury and hearing loss can result if proper gear is not worn.
4. Keep work area clear and where required **always** post warning signs when using the tool. Sign should state, "Powder Actuated Tool in Use" and can be obtained by contacting Technical Services at 1-877-489-2726.

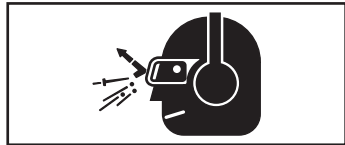
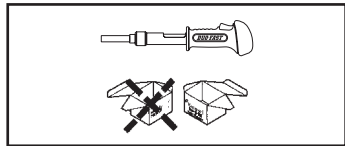
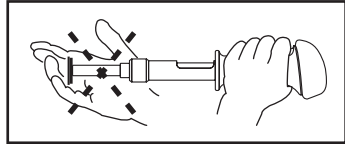

# SAFETY PRECAUTIONS

## Prepare for Loading

1. Prior to using the tool, make sure it is unloaded and then do the functional check: Check the functioning of the tool, without a powder load or fastener, by pushing down against the work surface and pulling the trigger. The trigger mechanism will make an audible click. Release the tool from the work surface and fully extend the barrel to reset the piston.

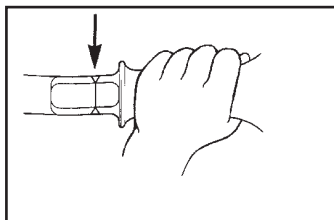

2. Always check the material being fastened into, by performing the Center Punch Test: Using a fastener as a center punch, strike the fastener against the work surface using an average hammer blow and check the results. Wear eye protection while performing this test.

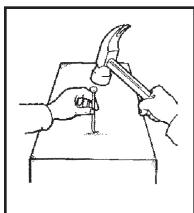

1. If the fastener point is blunted, material is too hard.

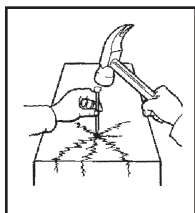

2. If material cracks or shatters, material is too brittle.

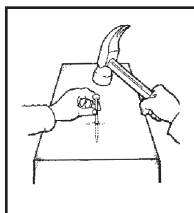

3. If the fastener penetrates the material easily, material is too soft.

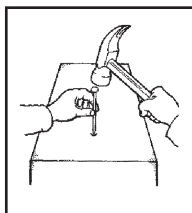

4. If the fastener makes small indentation into material, material is suitable for fastening.

(Typical base materials: poured concrete, structural steel and masonry.)

3. If the base material is suitable for powder actuated fasteners, make a test fastening into a suitable base material with a number 2 (brown), or lighter load. If the number 2 load does not fully set the fastener, try the next higher power load until the proper level is found. Failure to properly test fire to determine correct power level may result in overpowering the fastener, causing it to pass completely through the work material, injuring someone on the other side. Overpowering the fastener may also damage the tool.

### Power Levels Available for TriggerDrive:

Power Level No.	Color
1. Gray	Weakest
2. Brown	↓ Strongest
3. Green	
4. Yellow	

*NOTE: Duo-Fast loads are designed for use with Duo-Fast tools. Do not attempt to use other power loads. Doing so may lead to unintentional load discharge as well as damage to the tool. This tool is NOT designed to use red (5) or purple (6) power level loads. Using red (5) or purple (6) loads can result in serious injury to the operator or bystanders.*

# SAFETY PRECAUTIONS

# SAFETY PRECAUTIONS

## Operating the Tool

1. Always point the tool away from people and in a safe direction.

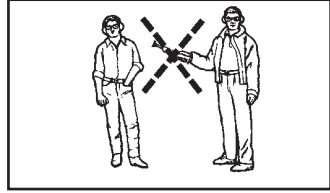

2. **Never** use tool when explosives or flammable materials are nearby.

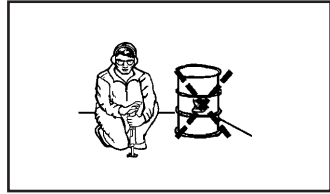

3. **Never** fire the tool without a fastener. The piston will protrude from the muzzle of the tool, enter the work surface and possibly cause injury to the operator or a bystander. Firing without a fastener may also damage the tool.

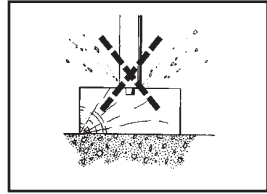

4. Always hold the tool perpendicular to the work surface to avoid serious injury or death from ricocheting fasteners. Use a spall guard\* whenever possible.

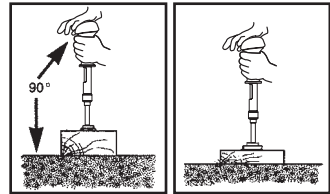

5. **Never** set a fastener too close to another fastening or a free edge. This can cause the fastener to ricochet. Always follow the minimum spacing and edge distance requirements.

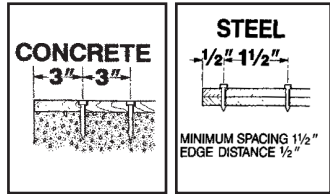

6. **Never** fire into very hard or brittle materials such as cast iron, tile, glass or rock. These materials can shatter, causing sharp fragments and/or the fastener to fly freely.

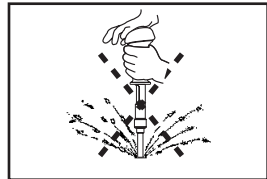

\*To order optional spall guard, call 1-877-489-2726

# SAFETY PRECAUTIONS

- Never** fasten into structural steel base material thinner than 3/16". Never fasten into concrete base material thinner than 3 times shank penetration. Always maintain minimum penetration requirements.
- Fastening into block and masonry is not recommended. When it is necessary to fasten into masonry walls, it is recommended that fasteners be driven into the horizontal joints only. Published holding values for these materials is not available due to the inconsistency of the materials.
- Never** fasten through or into a hole. Always maintain at least 1/2" distance from any pre-drilled or pre-punched hole.
- Should you decide not to make a fastening after the tool has been loaded, always remove the powder load first, then the fastener. **Never** attempt to pry an unfired load out of the tool. Call the Technical Department at 1-877-489-2726 for assistance.

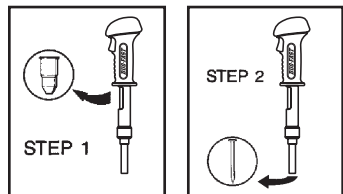
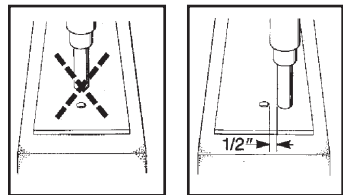
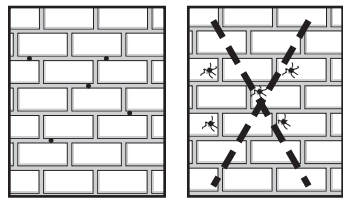
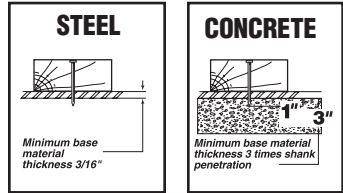

## Handling Tool and Powder Loads

- Never** leave a loaded tool unattended. Someone may pick it up, not know it is loaded and accidentally discharge the tool causing serious injury or death. **Never** load the tool until you are prepared to complete the fastening. **Always** store loads and tool, unloaded, under lock and key.

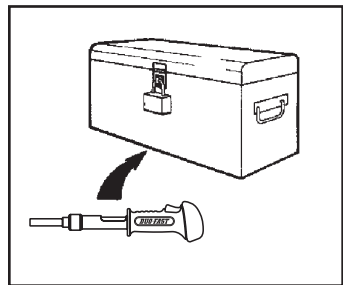

# SAFETY PRECAUTIONS

# SAFETY PRECAUTIONS

2. **Never** carry fasteners or other hard objects in the same pocket or container with powder loads. The loads could be set off, causing serious injury or death.
3. A person that is color blind must be extra careful when loading the tool. One must only take a load from a box that is identified by powder load number. **Never** use loose loads that can be misidentified.
4. Powder loads must never be used in firearms. They are more powerful than the charges normally used in small firearms. This could result in serious injury or death.

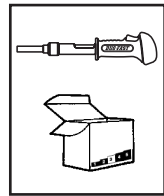
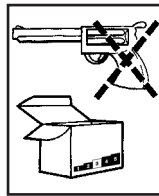
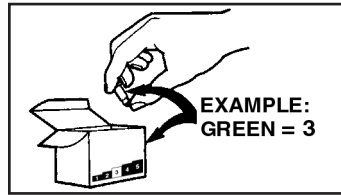
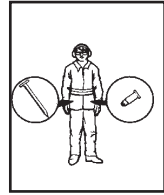
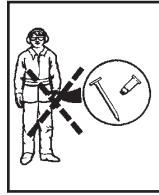

## Fasteners

1. A powder actuated fastener, after it has been installed, is considered a permanent fastening. Do not attempt to pull a fastener out of concrete or steel. Attempting to do so may result in serious injury.

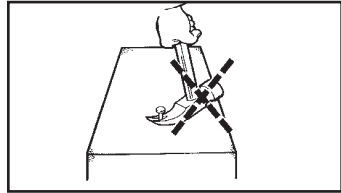

## Operating Problems

1. If the tool fails to fire, hold the tool firmly against the material for 30 seconds. Remove the tool from the work surface, open the barrel to reset the piston. Re-chamber the load and repeat firing sequence. If the tool fails to fire again, hold for 30 seconds, unload the tool, and then discard the load into a bucket of water. **Never** attempt to pry an unfired load out of the tool. Call the Technical Department at 1-877-489-2726 for assistance.

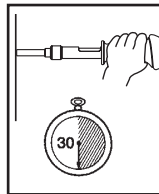

# SAFETY PRECAUTIONS

2. **Never** unload or disassemble a jammed, stuck or broken tool which contains a live powder load. This may cause the tool to fire unintentionally. Always point a jammed tool away from yourself and other people. Immediately store a jammed or broken tool in a locked container after tagging it "Defective - Do Not Use". Call 1-877-489-2726 for technical assistance.

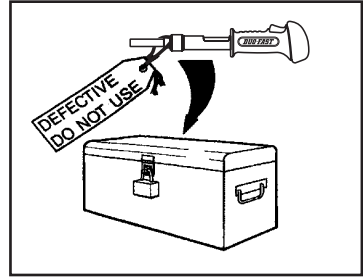

## DUOFAST FASTENER SELECTION GUIDE

<b>.300 Head Plastic Fluted Drive Pins</b>	
<b>Shank Length</b>	<b>Shank Diameter</b>
1/2"	.145
5/8"	.145
3/4"	.145
1"	.145
1-1/4"	.145
1-1/2"	.145
1-3/4"	.145
2"	.145
2-3/8"	.145
2-1/2"	.145

<b>.300 Head Plastic Fluted Drive Pin with 7/8" Washer</b>	
<b>Shank Length</b>	<b>Shank Diameter</b>
1"	.145
1-1/4"	.145
1-1/2"	.145
2"	.145
2-1/2"	.145
3"	.145

# TOOL OPERATION

**CAUTION!** Be sure to read and understand all safety precautions and complete the Operator's Exam before attempting to operate the tool. Check to be sure the tool is unloaded and no foreign objects or fasteners are in the barrel. Perform daily function test before operating.

## OPERATION

Check the functioning of the tool, **without a powder load or fastener** in the tool, by pushing down against the work surface and pulling the trigger. The trigger mechanism will make an audible click. Release the tool from the work surface and fully extend the barrel to reset the piston.

1. Point the tool in a safe direction and slide the barrel forward with your other hand. This action resets the piston for the next fastening. Loss of power may be the result of an improperly reset piston.
2. Place a fastener, point out, into the front end of the barrel until the plastic fluted tip fits inside. **Always load the fastener before inserting the power load to prevent accidental discharge.** Do not use excessive force when inserting the fastener. Stop if excessive force is required and call 1-877-489-2726 for technical assistance.

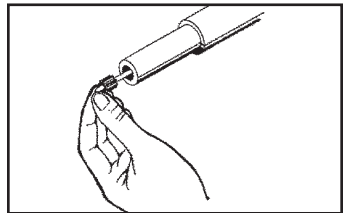
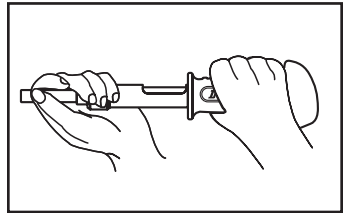

3. Insert the powder load after making sure the chamber is clear. The powder load will **not** fully set until the tool is compressed against the work surface. Always start with the lowest level and increase until the proper level is found. **Note: Overpowering a fastener into steel or concrete is dangerous.**

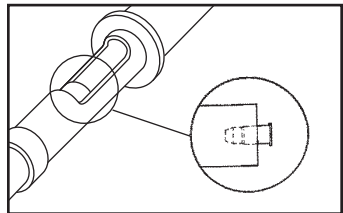

Note: Before making the fastening, the base material should be center punch tested for suitability of powder actuated fastenings (see pg. 2).

# TOOL OPERATION

4. Close tool by pulling the barrel back to the semi-closed position. Never attempt to close the tool by exerting force on the front of the barrel. Never place your fingers or hands over the muzzle end of the barrel. The proper position of the hands and fingers are shown in the illustration.

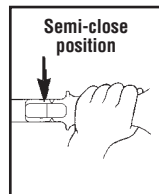
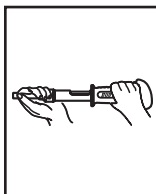

5. With the tool in the semi-closed position, place it against the material to be fastened. Hold the tool firmly at 90° and completely depress. The proper position of the hands and fingers are shown in the illustration.

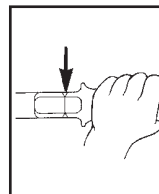
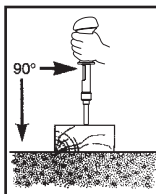

6. With the tool completely depressed, pull the trigger. Always hold the tool firmly and perpendicular to the work surface. Excessive recoil may be experienced if the tool is not held firmly against the work surface.

**Do not depress the tool in any manner except against the work surface.**

If the tool does not fire after pulling the trigger, hold the tool firmly against the material for 30 seconds. Remove the tool from the work surface, open the barrel to reset the piston. Re-chamber the load and repeat firing sequence. If the tool fails to fire again, hold for 30 seconds then remove the load and discard the load into a bucket of water.

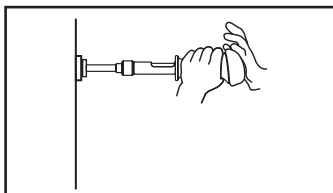

7. To prepare for the next fastening, point the tool in a safe direction, and slide the barrel firmly forward. This action ejects the fired load out of the tool and properly resets the piston. The tool is now ready for the next fastening.

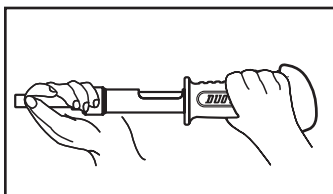

## CLEANING & MAINTENANCE

To maintain your tool in good working condition, refer to page 12 for cleaning and maintenance information. Call 1-877-489-2726 for service information.

# TROUBLESHOOTING

**Tool operator must carefully follow all operating instructions and precautions to successfully operate the tool. Following is a list of potential situations an operator may encounter and the probable causes:**

- If a tool problem occurs and technical assistance is required, please call 1-877-489-2726

**WARNING: Do not operate a tool that is not functioning properly.**

## CORRECTING DIFFICULTIES

### ALWAYS CHECK INSTRUCTION MANUAL FOR PROPER ASSEMBLY OF PARTS

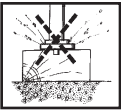
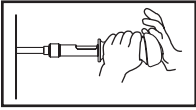
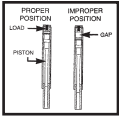
DIFFICULTY	PROBABLE CAUSE	REMEDY
<b>Over driving of fastener</b> (Piston overdrive) 	Excessive power Soft base material	Change to next lower power level load color and number (see pg. 2) Check base material (see pg. 2)
<b>Tool fails to fire</b> 	Failure to depress tool completely Excessive dirt build up on firing mechanism. Damaged firing mechanism.	Tool must be held firmly and completely depressed before pulling the trigger Call 1-877-489-2726 for technical assistance
<b>Tool does not completely depress</b>	Misassembled or damaged firing mechanism parts	Call 1-877-489-2726 for technical assistance
<b>Reduction or loss of power or inconsistent fastener penetration</b> 	Barrel not returning to full front position Worn or damaged piston or piston ring	Barrel must be pulled completely forward to properly position the piston Call 1-877-489-2726 for technical assistance
<b>Fired cartridge will not extract</b>	Tool not being opened completely Bent piston or damaged piston ring Broken ejector tip on piston Build-up of dirt in load chamber Stuck fired load	Spray with penetrating oil, then firmly snap the tool open Call 1-877-489-2726 for technical assistance Use long nose pliers to remove the fired cartridge. Clean chamber with penetrating oil and wire brush Call 1-877-489-2726 for technical assistance

# TROUBLESHOOTING CONT.

DIFFICULTY	PROBABLE CAUSE	REMEDY
<b>Unfired load will not extract</b>	Load stuck in chamber	Call 1-877-489-2726 for technical assistance. Never attempt to pry a load from the chamber.
<b>Tool cannot be cocked</b>	Lack of proper cleaning	Clean tool thoroughly
	Damaged or bent piston	Call 1-877-489-2726 for technical assistance
	Broken or damaged tool parts	Tag tool with warning "Defective - Do Not Use", place tool in locked container and call 1-877-489-2726 for assistance
<b>Piston stuck in down position</b>	Piston overdriven and stuck in muzzle bushing	Be sure tool is unloaded, tap on hard surface or drive piston back with a lead or brass hammer. Wear safety goggles.
<b>Chipped or damaged piston tip</b>	Tool not held on work surface squarely. This allows the piston to slip off the head of the pin and cause damage to the piston.	Call 1-877-489-2726 for technical assistance
<b>Barrel tight, won't slide open easily</b>	Bent piston	Call 1-877-489-2726 for technical assistance
	Excessive carbon buildup	Disassemble and clean tool with penetrating oil and wire brush
	Pieces of brass or steel jammed between the barrel	Disassemble and clean affected area
<b>Barrel slides open too easily</b>	Tang cap screw loose	Tighten tang cap screw
	Tang weak or missing	Replace tang

## Fastening to Concrete

When fastening into concrete always maintain a minimum 3" spacing between fastenings and 3" from any free edge. Penetration into concrete should always be 1" minimum (see page 15, "How to Select a Powder Actuated Fastener"). The concrete thickness should be at least 3 times the penetration depth.

## Fastening to Steel

When fastening into steel always maintain a minimum 1-1/2" spacing between fastenings and 1/2" from any free edge. Fastener length should be long enough to penetrate the steel completely (see page 15) Steel thickness is limited to 3/16" to 5/16".

# TROUBLESHOOTING CONT.

# APPLICATIONS

## Wood to Concrete

7/8" washer provides a greater bearing surface to the wood member, minimizing uplift.

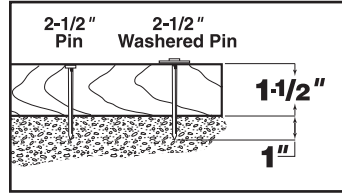

## Wood to Steel

Fastener should penetrate steel completely for maximum holding power.

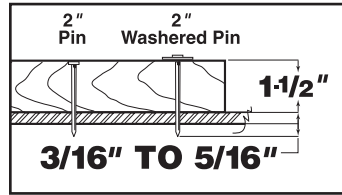

## Furring Strip to Concrete or Masonry Walls

When fastening into masonry, shoot into horizontal joints only.

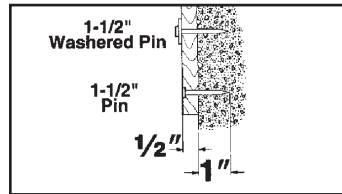

## Thin Gauge Metal to Concrete or Masonry

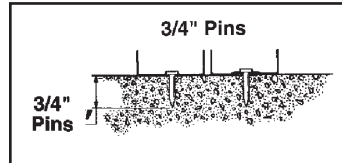

## Thin Gauge Metal to Steel

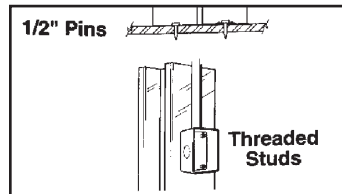
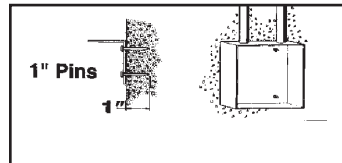

# CLEANING AND MAINTENANCE

## PROPER MAINTENANCE AND CLEANING INSTRUCTIONS

Make sure the tool is not loaded prior to attempting disassembly or cleaning.

### DAILY FUNCTION TEST

Check the functioning of the tool, without a powder load or fastener, by pushing down against the work surface and pulling the trigger. The trigger mechanism will make an audible click. Release the tool from the work surface and fully extend the barrel to reset the piston.

## DAILY MAINTENANCE AND CLEANING

Wear eye protection when cleaning the tool. Check all areas of tool for debris or rust that could restrict safe operation of moving parts. Do not operate any tool that shows signs of rust on any surface as this may interfere with the safe operation of the tool. Call 1-877-489-2726 for technical assistance. The barrel assembly and housing should be cleaned of excess dirt and debris on a daily basis. After each use, spray a quality penetrating lubricant on indicated areas before storing tool.

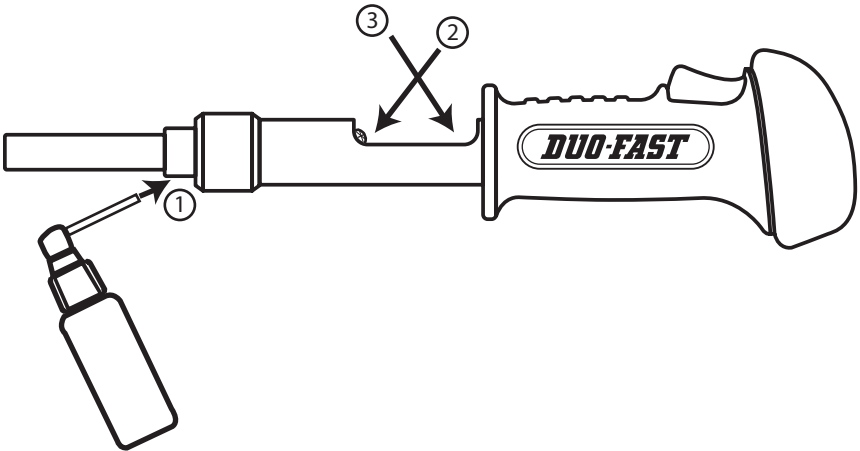



# Trigger Drive

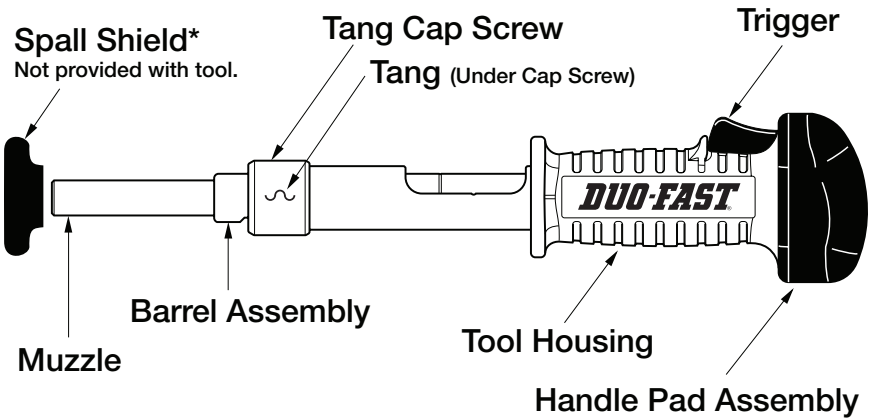

# HOW TO SELECT A POWDER ACTUATED FASTENER

## DETERMINE FASTENER TYPE

Drive pins are used to directly fasten an object (permanent installation). Threaded studs are used where the object fastened may later be removed or where shimming is required. The following shows how to determine shank and thread length:

### PERMANENT INSTALLATION

#### 1A To Concrete

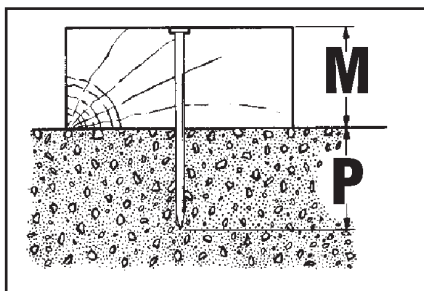

$$\text{Minimum Shank Length} = \text{Thickness of Material (M)} + \text{Required Penetration (P)}$$

#### 1B To Steel

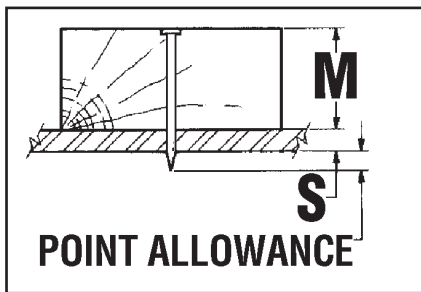

$$\text{Minimum Shank Length} = \text{Thickness of Material (M)} + \text{Thickness of Steel (S)} + \frac{1}{4} \text{ min. pt. allowance}$$

### REMOVABLE INSTALLATION

#### 2A To Concrete

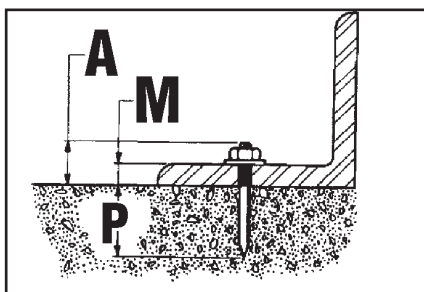

$$\text{Thread Length (A)} = \text{Thickness of Material (M)} + \text{Allowance* for Nut \& Washer}$$

$$\text{Shank Length} = \text{Required Penetration (P)}$$

#### 2B To Steel

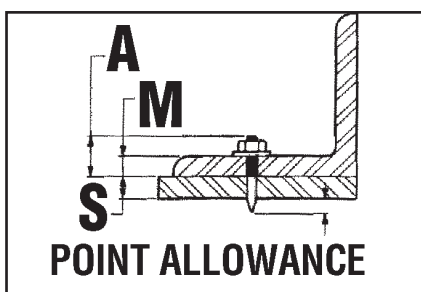

$$\text{Thread Length (A)} = \text{Thickness of Material (M)} + \text{Allowance* for Nut \& Washer}$$

$$\text{Shank Length} = \text{Minimum Thickness of Steel (S)} + \frac{1}{4} \text{ min. pt. allowance}$$

\*Allowance for thickness of nut & washer = thread size (i.e. allow 1/4" for 1/4-20 thread, etc.)

## SAFETY PRECAUTIONS

# OPERATOR'S EXAMINATION

After studying and understanding the material in this tool manual, answer the following questions. Complete the information on the other side of this page. Enclose a copy of your sales receipt and send to the address on the back of this manual to activate your tool warranty and receive your tool license.

1. Safety goggles and hearing protection must always be worn by the operator and any necessary bystanders when using the tool.  
 True  False
2. The strongest power level should be tried first when making the first fastening.  
 True  False
3. Never attempt to fire the tool until the muzzle end is compressed against the work surface and you are ready to make a fastening.  
 True  False
4. Sheet rock, drywall board, wood, fiberglass, ceramic tile, brick and thin sheet metal are examples of materials not to be fastened into.  
 True  False
5. A powder actuated tool can be safely used in an explosive or flammable atmosphere.  
 True  False
6. Malfunctioning tools can be used and do not have to be removed from service immediately.  
 True  False
7. When operating a powder actuated tool, your hand should never be placed in front of the tool muzzle.  
 True  False
8. Poured concrete and structural steel are suitable materials for fastening into.  
 True  False
9. To determine the suitability of a base material, use a fastener as a center punch as follows:  
A) If the fastener is blunted, do not fasten; the material is too hard.  True  False  
B) If the fastener penetrates easily, do not fasten; the material is too soft.  True  False  
C) If the material cracks or shatters, do not fasten; the material is too brittle.  True  False
10. In concrete, a fastener should be driven no closer to a free edge than 3".  
 True  False
11. When fastening into concrete, the base material should be greater than the shank penetration by at least 3 times.  
 True  False
12. Do not drive fasteners into steel that is thinner than 3/16".  
 True  False
13. Powder actuated tools, fasteners and loads, must always be kept in a secure, locked area when not in use to avoid access by unauthorized persons.  
 True  False
14. When considering the safety of a particular application, the operator must think about all of the following: a) the powder load power level, b) the operator's safety, c) the safety of bystanders and fellow workers, d) the base or receiving material.  
 True  False
15. It is not necessary to read the Operator's Manual prior to operating the TriggerDrive low velocity powder actuated tool.  
 True  False
16. The best way to check the receiving material is to set several fasteners using the most powerful load.  
 True  False
17. Piston overdrive is caused by overpowering of the tool or by discharging the tool against a soft surface.  
 True  False
18. One should never attempt to pry a stuck load out of a tool.  
 True  False
19. Placing a hand over the muzzle end of a loaded tool can result in serious injury from piston overdrive or an escaping fastener if the tool is discharged accidentally.  
 True  False

Signed \_\_\_\_\_

Date \_\_\_\_\_

# LICENSE AND WARRANTY ACTIVATION

The TriggerDrive Tool is warranted for 90 days after sale by ITW Brands.

I certify that I have read and understand the TriggerDrive Tool Operator's Instruction and Training Manual and have taken the Operator's Exam on the reverse side.

*(Please Print Clearly)*

The serial number on my tool is: \_\_\_\_\_

***Please send my tool license to:***

Name \_\_\_\_\_

Address \_\_\_\_\_

City \_\_\_\_\_ State \_\_\_\_\_ Zip \_\_\_\_\_

Phone \_\_\_\_\_

Email \_\_\_\_\_

Yes. I would like to receive product updates and information from Duo-Fast.

## **RETURN TO:**

### **In USA**

ITW Brands  
ATTN: License Coordinator  
955 National Parkway, Suite 95500  
Schaumburg, IL 60173