



DANGER!

THIS TOOL IS FOR USE ONLY BY LICENSED OPERATORS ONLY. READ AND OBEY ALL SAFETY OPERATING INSTRUCTIONS BEFORE OPERATING TOOL.

DUO-FAST[®]
CONSTRUCTION

DF-27

***SEMI-AUTOMATIC, LOW VELOCITY,
PISTON-TYPE FASTENING TOOL***

***Operator's Safety & Operating
Instruction Manual***



• *Do not operate the DF-27 before studying this manual carefully and thoroughly understanding the material contained herein.*

IMPORTANT: *The tool warranty is only activated upon receipt by ITW Brands of the completed Operator's Exam.*

**DANGER**

**THIS TOOL IS TO BE USED ONLY BY PROPERLY TRAINED
AND LICENSED OPERATORS.**

**YOU MUST SUCCESSFULLY COMPLETE THE DUO-FAST TRAINING
PROGRAM FOR THE TOOL AND OBTAIN A CERTIFIED
OPERATOR'S LICENSE BEFORE HANDLING, LOADING, OR
OPERATING THIS TOOL.**

**ATTEMPTING TO HANDLE OR OPERATE THIS TOOL
WITHOUT PROPER TRAINING AND LICENSING CAN RESULT IN
SERIOUS INJURY TO THE OPERATOR OR BYSTANDERS.**

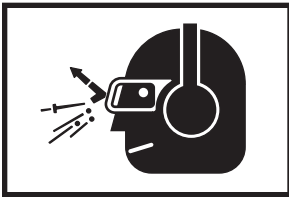

**Operators and bystanders
must wear eye and hearing
protection.**

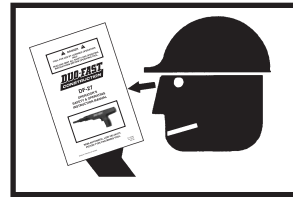

**Read manual before
operating tool.**



**Never close tool with hand over fastener loading end of the tool.
A serious hand injury from penetration by the piston or a
discharged fastener could result.**

**DANGER**

Just as no one can merely read a book about driving an automobile and then hope to drive one safely, no one should attempt to use any Duo-Fast tool without adequate, competent, personal instruction. And just as one must be licensed to drive an automobile, one must also be licensed to use a powder actuated tool. No automobile instruction book or instructor can forewarn a learner against all possibilities and emergencies, nor can Duo-Fast instructors and printed material detail all possible conditions surrounding the use of Duo-Fast tools and products.

**Responsibility for the safe and proper use of this tool rests with the tool user
and the employer.**

Preparation

Acceptable Base Materials

Powder-actuated fastening is suitable for use in the following base materials only:

- Poured Concrete
- Structural Steel
- Masonry Joints (see page 8)

Never attempt to fasten into any other type of material. Fastening into other materials can cause blindness or other serious injury.

Unacceptable Base Materials

Never attempt to fasten into very hard or brittle materials such as cast iron, tile, glass, or rock of any type. These materials can shatter, causing the fastener and/or base material fragments to fly free and cause serious injury to tool operator and others.

Never fasten into soft base materials, such as drywall or lumber products. These materials may allow the fastener to travel completely through and out the other side, endangering those in the path of the fastener.

Never fasten into any base material that does not pass the Center Punch test.

Failure to assure the suitability of the base material can result in serious injury to the eyes or other body parts.

Center Punch Test

ALWAYS WEAR SAFETY GOGGLES WHEN PERFORMING THIS TEST.

1. Always check the material being fastened into for hardness before attempting any fastening operation.
2. Using a fastener as a center punch, strike the fastener against the work surface using an average hammer blow and check the results.

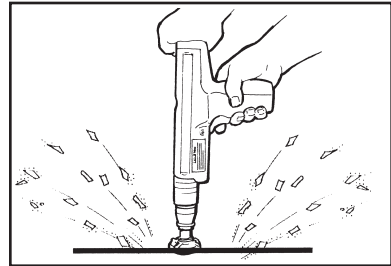

NEVER FASTEN INTO VERY HARD OR BRITTLE MATERIALS

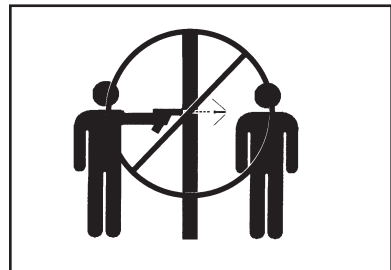

NEVER FASTEN INTO SOFT MATERIALS SUCH AS DRYWALL

Center Punch Test Results

1. If the fastener point is flattened, the material is too hard for a powder actuated fastening.
2. If the fastener penetrates the material easily, the material is too soft.
3. If the material cracks or shatters, the material is too brittle.
4. If the fastener makes a small indentation into the material, the material is suitable for fastening.

SAFETY INSTRUCTIONS

⚠ DANGER

Loads and Load Selection Safety

1. **Always make a test fastening after being sure that the base material is suitable for powder actuated fastening.** *Failure to determine the correct power level to be used may result in the use of excessive power, allowing the fastener to pass completely through the work material, causing serious or fatal injuries to others who may be in the path of the fastener.*
2. **Color-blind operators must always select loads by load number to prevent use of an incorrect load for the same reasons as in #1 above.**

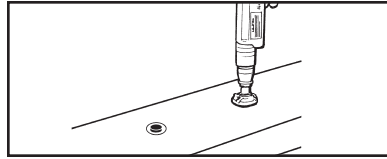

ALWAYS MAKE A TEST FASTENING

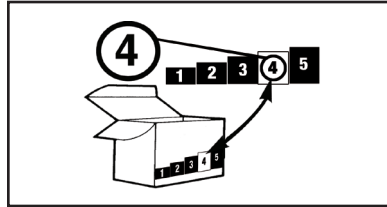

COLOR-BLIND OPERATORS MUST ALWAYS SELECT LOADS BY NUMBER

Workplace Safety

1. **Operators and bystanders must always wear approved eye protection and approved hearing protection.** *Failure to do so may result in blindness or serious eye injury from flying debris and loss of hearing from constant or repeated unprotected exposure to fastening noise.*
2. **Always keep the work area clear of bystanders and unnecessary materials that could interfere with safe tool operation.** *Operating the tool in a congested or cluttered area may affect your ability to operate the tool safely.*
3. **Never operate tool if flammable or explosive materials are nearby.** *Powder loads burn and create sparks when fired and could ignite these materials or fumes.*
4. **Always post warning signs within 50 ft. of the area where fastening is to be done. Sign must state: "WARNING – Powder Actuated Tool In Use".** *Failure to warn others may result in serious injury to them. Contact ITW Brands at 1-877-489-2726 to obtain this sign.*



KEEP WORK AREA CLEAR OF BYSTANDERS & CLUTTER



NEVER OPERATE THE TOOL AROUND FLAMMABLE OR EXPLOSIVE MATERIALS



ALWAYS POST WARNING SIGNS

SAFETY INSTRUCTIONS

⚠ DANGER

SAFETY INSTRUCTIONS



Tool Handling Safety

1. Always be sure tool is operating properly before attempting to use it. Follow the “Daily Function Check” shown to the right and described on page 9.
2. Always load tool using a strip load selected directly from a box indicating the power load type and number. Never attempt to use loose strip loads that could be misidentified.
3. Never carry loose strip loads in pockets with pins or other hard objects.
4. Never load a tool unless you intend to immediately make a fastening. *Loading a tool and leaving it unattended in the work area can result in the tool being accidentally discharged by others.*
5. Never place your hand or any other body part over the fastener loading end of tool. *Serious hand injury can result from being struck by either a fastener or the tool piston should the tool be accidentally fired.*
6. Always store tool unloaded and keep the tool and the loads securely locked in a tool box. Keep keys away from children and unlicensed persons.
7. Always keep the tool pointed away from yourself and others.
8. Never carry a loaded tool around the work area.
9. Never allow anyone not trained to use the tool.
10. Never engage in horseplay with the tool.
11. Using the tool in poorly ventilated areas, cleaning tool or handling loads may result in exposure to lead or other substances known to cause birth defects, and other physical harm. Have adequate ventilation at all times and wash thoroughly after exposure.

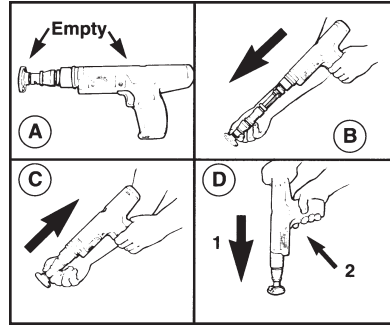

ALWAYS DO A DAILY FUNCTION CHECK BEFORE LOADING THE TOOL

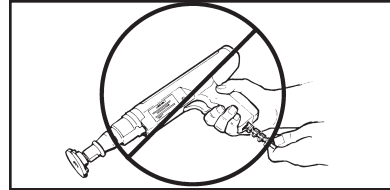

NEVER LOAD TOOL UNLESS IT IS TO BE USED IMMEDIATELY

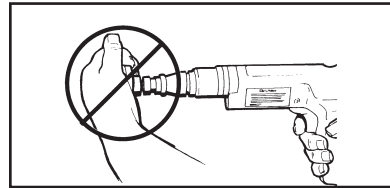

NEVER PLACE HANDS OR BODY OVER MUZZLE OPENING

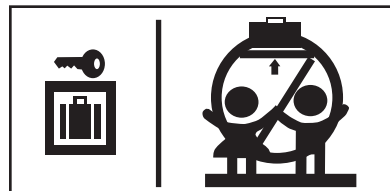

KEEP TOOL LOCKED & OUT OF THE REACH OF CHILDREN



SAFETY INSTRUCTIONS

SAFETY INSTRUCTIONS

⚠ DANGER

FAILURE TO FOLLOW INSTRUCTIONS CAN CAUSE INJURY TO THE TOOL OPERATOR OR TO BYSTANDERS.

Fastener Driving Safety

1. Only use the tool for fastening into a suitable base material.
2. Never fire the tool without a fastener. *Firing a tool without a fastener will cause the piston to strike the work surface, and may cause serious injury to you and others in the work area.*
3. Always use the spall guard whenever possible to minimize flying particles or debris.
4. Always hold the tool perpendicular to and firmly against the work surface when making a fastening. *Failure to do so could allow a fastener to ricochet.*
5. Never attempt to drive a fastener close to an edge or to another fastener. See page 8 for guidelines.

ALWAYS FOLLOW THE MISFIRE PROCEDURE.

If the tool does not fire after the normal firing sequence, continue to hold the depressed tool against the work surface for at least 30 seconds. Then carefully lower the tool, remove the strip load and put it in a can of water or other non-flammable liquid. Never carelessly discard a strip with live loads into a trash container.

If the tool becomes stuck or jammed with a live powder load, keep the tool pointed in a safe direction, and immediately tag it, “**Danger—defective—do not use**”. Lock the tool in a tool box and call 1-877-489-2726 for technical assistance.

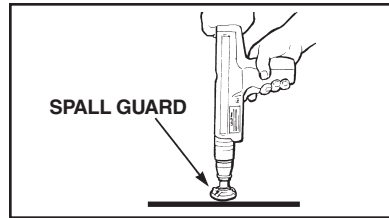

USE SPALL GUARD WHENEVER POSSIBLE

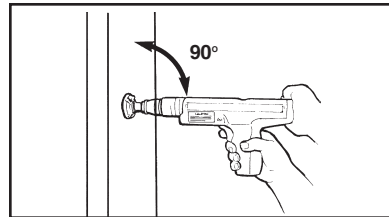

ALWAYS HOLD THE TOOL PERPENDICULAR TO THE WORK SURFACE

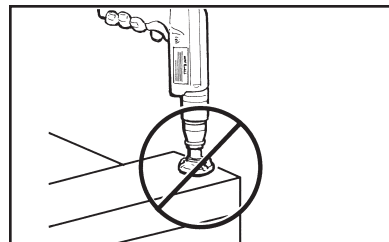

NEVER DRIVE A FASTENER CLOSE TO AN EDGE

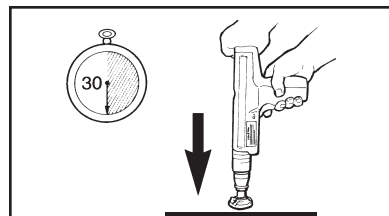

HOLD TOOL FIRMLY AGAINST THE WORK SURFACE FOR AT LEAST 30 SECONDS.

SAFETY INSTRUCTIONS

⚠ DANGER

FASTENERS / LOADS

Your Duo-Fast DF-27 tool uses only the Duo-Fast fasteners and loads shown below or listed for the tool in the Product Catalog.



DANGER



Never use other types of fasteners or strip loads in the Duo-Fast DF-27 tool. Use of other types of fasteners or loads may cause unintentional load discharge, damage the tool, cause poor fastening performance, or create a risk of serious injury to the operator or bystanders.

FASTENERS

.300 HEAD PLASTIC FLUTED DRIVE PINS



.145 Shank Diameter in Shank lengths from 1/2" to 3"

.300 HEAD PLASTIC FLUTED DRIVE PINS WITH 7/8" WASHER

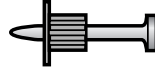

.145 Shank Diameter in Shank Lengths from 1" to 3"

1/4" - 20 THREADED STUDS

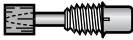

.145 Shank Diameter in Shank Lengths of 1/2" and 1" and thread lengths of 1/2", 3/4" and 1"

.300 HEAD POWER POINT PLASTIC FLUTED DRIVE PINS



.150 Straight Shank in Shank Lengths from 1/2" to 7/8"
.150/.180 Step Shank in Lengths from 1" to 1-7/8"

8 mm HEAD TOP-HAT DRIVE PINS



.145 Shank Diameter in Shank Lengths from 1/2" to 1"

CEILING CLIP ASSEMBLIES



CONDUIT CLIP ASSEMBLIES



For 1/2" and 3/4" Diameter Conduit with 1" Pre-mounted Fastener

Ceiling Clip with 1" or 1-1/4" pre-mounted .145 Shank Pin and Ceiling Clip with 1" or 1-1/4" pre-mounted .150/.180 shank pin.

LOADS

Duo-Fast 27 cal. strip loads are made for use in the Duo-Fast DF-27 Tool.



DUO-FAST 27 CAL. 10 SHOT STRIP LOAD

The power level of the load is indicated by the number marked on each box, the color of the box, and the color on the tip of each load. As the number increases, the power level also increases.

POWER LEVEL	LOAD COLOR	CASE COLOR
3	Green	Brass
4	Yellow	Brass
5	Red	Brass
6	Purple	Brass

Always perform the center punch test described on page 3 to test the base material.

Always make a test fastening using the lowest power level first. If more power is required to set the fastener, use the next higher power level until the powder level necessary to drive the fastener is reached.

FASTENERS / LOADS

FASTENING APPLICATIONS

FASTENING APPLICATIONS

Your Duo-Fast tool can be used for a wide range of fastening needs in a variety of base materials. Reading and following these important fastening guidelines will help you get the best results from your tool, fasteners, and powder loads, as well as help you perform these fastening operations safely and effectively.

Powder actuated fastenings are permanent fastenings so attempting to remove a fastener from concrete or steel may result in serious injury.

Fastening to Concrete

When fastening into concrete, always maintain a minimum spacing of 3" between fastenings and 3" from any free edge. Concrete thickness should be at least three times the intended penetration depth into the concrete. The primary exception to the 3" edge distance can occur in a sill plate application where, by necessity, the edge distance is reduced.

Driving fasteners too close to an edge or too close to each other can cause the concrete edge to fail or fasteners to fly free.

Fastening to Concrete Block or to Masonry Walls

While this application is not recommended, when used, it is necessary to take care to observe a 3" edge distance to avoid cracking the block and over penetration of the fastener to avoid loss of holding value. Fastenings may be made into the horizontal joint but not into the vertical joint.

Fastening to Steel

Your Duo-Fast tool can be used for fastening on the flat surfaces of structural steel. When fastening into steel, always maintain a minimum spacing of 1-1/2" between fastenings and 1/2" from any edge.

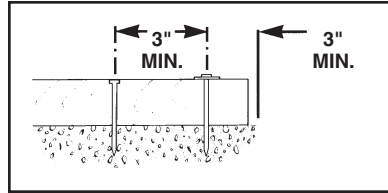

SPACING WOOD TO CONCRETE

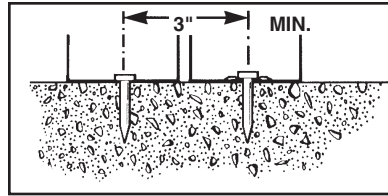

PENETRATION – THIN GAUGE METAL TO CONCRETE

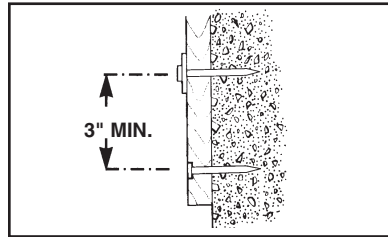

SPACING – FURRING STRIP TO CONCRETE

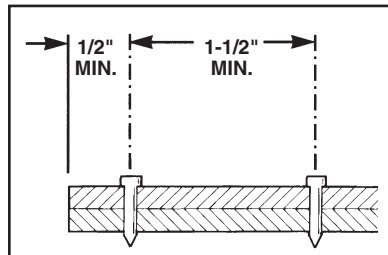

SPACING — STEEL TO STEEL

FASTENING APPLICATIONS

TOOL OPERATING INSTRUCTIONS

TOOL OPERATION

Daily Function Test

Always check the tool first to make sure it does not contain a strip load or fastener. Test the tool several times by depressing the muzzle bushing fully on a hard surface and pulling the trigger. You should hear an audible click as the firing pin releases. Let up on the tool, and check to be sure the barrel has opened to the fully extended position.

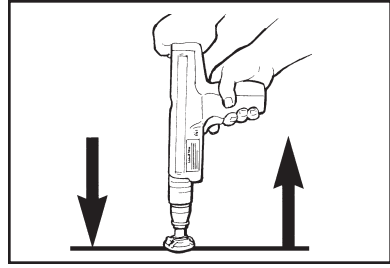

PERFORM THE FUNCTION TEST WITH EMPTY, UNLOADED TOOL

OPERATING THE DUO-FAST DF-27 TOOL

1. After checking to be sure that the tool is not loaded, point it in a safe direction and be sure that the barrel is fully extended and then close the tool to the closed position. This assures that the piston is in position for the next fastening. Use the spall guard every time possible to minimize the risk of being struck by flying debris.
2. With finger off the trigger, place the fastener, point out, into the muzzle end of the tool until the point end is inside the muzzle. **NEVER** load a fastener with your finger on the trigger. **DO NOT** use excessive force when inserting a fastener. **STOP** immediately if excessive force is required, inspect the barrel to find out why the fastener is not entering the muzzle freely. **DO NOT** continue loading unless the problem is corrected.
3. With the tool pointed in a safe direction and finger away from the trigger, insert a strip load into the bottom of the handle and push it in until your finger is in firm contact with the handle recess.

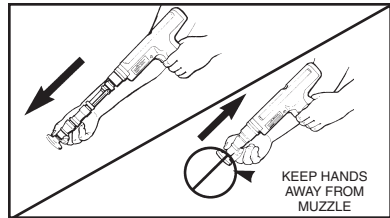

FULLY OPEN AND CLOSE TOOL TO THE CLOSED POSITION

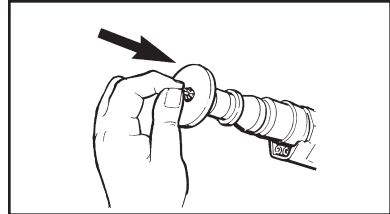

INSERT FASTENER INTO THE MUZZLE END OF THE TOOL WITH THE POINT OUT

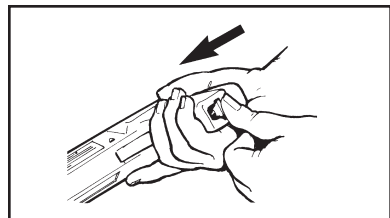

INSERT LOAD STRIP INTO THE OPENING IN THE BOTTOM OF THE HANDLE

TOOL OPERATING INSTRUCTIONS

TOOL OPERATING INSTRUCTIONS

4. Hold the tool perpendicular (90°) to the work surface with both hands, and press down firmly to fully depress the tool. Maintain firm downward pressure on the tool with both hands and pull the trigger to drive the fastener. **DO NOT DEPRESS THE TOOL AGAINST ANYTHING OTHER THAN THE INTENDED WORK SURFACE.** Holding the tool firmly in place while fastening will produce more consistent fastening quality, and minimize tool wear or damage.

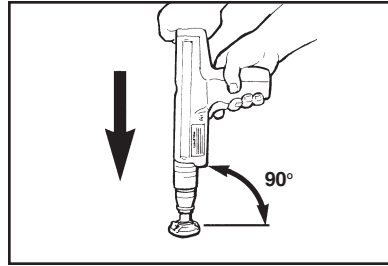

HOLD THE TOOL FIRMLY AND PERPENDICULAR TO THE WORK SURFACE

5. After making the fastening, fully open and then close the tool. This resets the piston and indexes a new load into place for the next fastening.
6. Insert another fastener in the muzzle end of the tool as before and the tool is ready for the next fastening. Keep your finger off of the trigger until the tool is in position to drive the fastener.

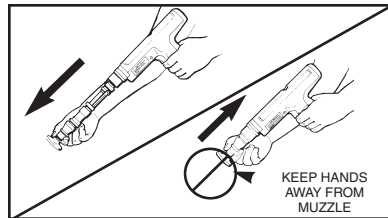

FULLY OPEN AND CLOSE TOOL TO THE CLOSED POSITION

7. To remove a used or partially used load strip from the tool, pull the strip out from the top of the tool. Do not try to remove the strip by pulling it out from the bottom of the handle. **NEVER** try to remove a jammed or stuck load strip. Should a “jammed” load strip occur, call 1-877-489-2726 for technical assistance.

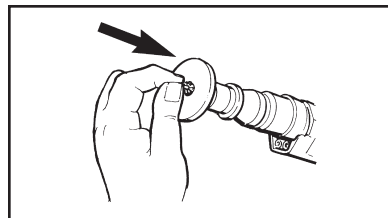

INSERT THE NEXT FASTENER

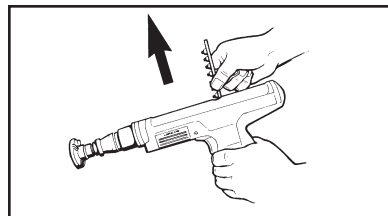

REMOVE THE LOAD STRIP ONLY FROM THE TOP OF THE TOOL

TOOL OPERATING INSTRUCTIONS

TROUBLESHOOTING

REFER TO PARTS SCHEMATIC FOR PROPER ASSEMBLY OF PARTS

– Overdriving of fasteners	– Excessive power	– Change to next lower power level load strip color and number
	– Soft base material	– Check base material (see page 3)
– Tool fails to fire	– Failure to depress completely	– See “Tool does not completely depress”
	– Dirt build-up on sear not allowing proper penetration of firing pin or worn firing pin.	– Check firing pin mark on power load. Clean firing pin guide, sear, and firing pin. Replace worn or damaged parts. Notice: Do not attempt to clean power load strip channel with wire brush. You may damage the tool.
– Tool does not completely depress	– Misassembled or damaged parts	– Check all parts in the receiver for damage or improper assembly
– Reduction or loss of power	– Piston not being returned to the full rear position	– Barrel must be pulled completely open to properly position the piston
	– Worn or damaged piston or piston ring	– Replace worn or damaged parts
– Tool cannot be cocked or opened	– Excessive dirt buildup	– Clean tool thoroughly
	– Damaged or bent piston	– Replace piston
	– Broken or damaged parts	– Tag tool with warning “Defective—Do Not Use”. Place in a locked container and call 1-877-489-2726 for service
– Failure to index strip	– Strip not inserted in tool correctly or is damaged	– Check load strip. Properly dispose of damaged strip. (see page 6)
	– Damaged indexing mechanism	– Call 1-877-489-2726
– Failure of tool to stay closed when held in the downward position	– Retaining ball missing	– Call 1-877-489-2726

TROUBLESHOOTING

PARTS SCHEMATIC / PARTS LIST

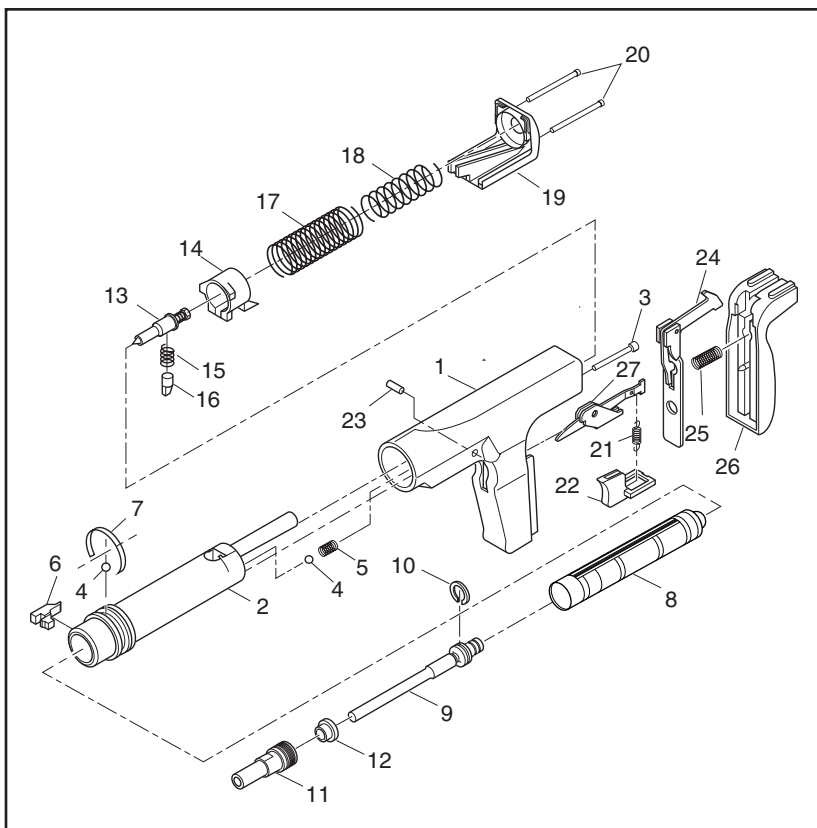

DF-27 TOOL PARTS LIST

KEY	PART NO.	DESCRIPTION	QTY.
1	490111	HOUSING	1
2	502100	OUTER LINER ASSEMBLY	1
3	501104	PUSH PIN	1
4	301013	BALL SETTER	2
5	501106	SPRING BALL SET	1
6	501107	KEY STOP	1
7	301014	ANNULAR SPRING	1
8	490310	BARREL	1
9	490320	PISTON ASSEMBLY (INCLUDES RING)	1
10	490322	RING	1
11	490312	3" MUZZLE CAP	1
12	490314	PLASTIC BUFFER	1
13	501300	FIRE PIN ASSEMBLY (INCLUDES PIN, SPRING, NUT, WASHER)	1

PARTS SCHEMATIC / PARTS LIST

PARTS LIST / MAINTENANCE

DF-27 TOOL PARTS LIST

KEY	PART NO.	DESCRIPTION	QTY.
14	501317	FIRING PIN GUIDE	1
15	301047	SPRING	1
16	501319	SEAR	1
17	501320	SPRING	1
18	501321	SAFETY SPRING	1
19	490735	REAR PAD	1
20	501423	BOLT	2
21	301531	ADVANCE SPRING	1
22	301533	TRIGGER	1
23	501526	TRIGGER PIN	1
24	502600	ROCKER ARM ASSEMBLY (INCLUDES ROCKER ARM, ROCKER ARM PIN, AND ROCKER ARM HOLDER)	1
25	501733	ROCKER ARM SPRING	1
26	490700	HANDLE PAD ASSEMBLY	1
27	501500	ADVANCE ASSEMBLY (HOLDER, BAR, TUBE)	1

ACCESSORIES (INCLUDED IN CASE)

PART NO.	DESCRIPTION	QTY.
490737	SPALL SHIELD	1
459089	BRUSH	1
501801	HEX WRENCH, 3MM	1
302005	SAFETY GOGGLES	1
490314	BUFFER	1

MAINTENANCE

**IMPROPERLY MAINTAINED TOOLS CAN CAUSE SERIOUS INJURIES
TO TOOL OPERATORS AND BYSTANDERS
CLEAN TOOL DAILY**

Always make sure tool is not loaded before performing any service or repair and always wear safety goggles when cleaning or servicing the tool.

NORMAL CLEANING

All front end parts shown in the disassembly section are to be cleaned daily with a good detergent oil and wire brush. Remove all dirt and carbon buildup and wipe parts dry with a clean rag. Check all parts for wear or damage before reassembly and replace or repair any worn or damaged parts. **NOTICE: Do not attempt to clean power load strip channel with wire brush. You may damage the tool.**

COMPLETE CLEANING / GENERAL MAINTENANCE

Heavy or constant exposure to dirt and debris may require that the tool be cleaned more extensively. Complete disassembly and cleaning of all parts may be necessary to restore the tool to normal operation. General maintenance should be performed every six months or more often if the tool is subjected to heavy use. Call 1-877-489-2726 for technical assistance.

**ALWAYS FUNCTION TEST THE TOOL AFTER PERFORMING ANY
SERVICE. SEE PAGE 9 FOR DETAILS ON THE FUNCTION TEST.**

PARTS LIST / MAINTENANCE

DISASSEMBLY

TOOL DISASSEMBLY

⚠ WARNING: ALWAYS unload a powder actuated tool before disassembling, replacing barrel, cleaning, or assembling.

TOOL DISASSEMBLY

A. REMOVING BARREL ASSEMBLY

1. Using screwdriver, lift end of annular spring and rotate spring until stop is uncovered (see Figure 1).

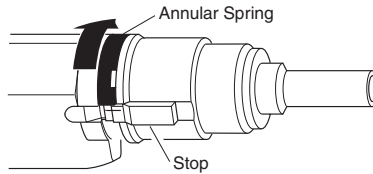

Figure 1 - Rotating Annular Spring to Uncover Stop

2. Push stop towards rear of tool and remove (see Figure 2).

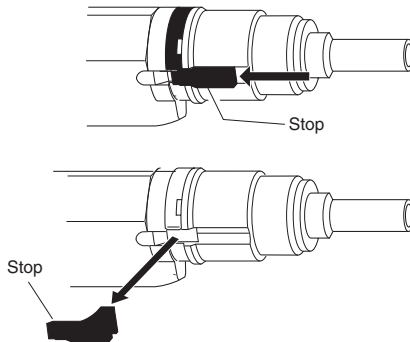

Figure 2 - Removing Stop

3. Pull barrel assembly out of housing.
4. Unscrew muzzle cap.
5. Pull buffer out of muzzle cap (see Figure 3).
6. Remove piston assembly from barrel (see Figure 4).

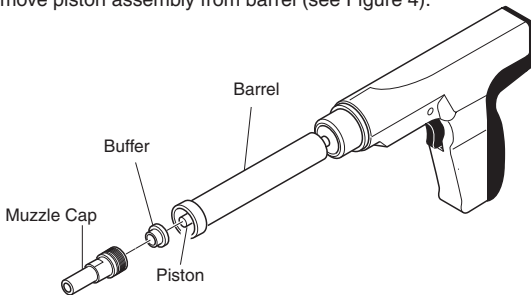

Figure 3 - Separating Barrel Assembly from Housing

DISASSEMBLY

B. REMOVING REAR PAD AND HANDLE PAD ASSEMBLY

Figure 4 - Removing Piston Assembly from Barrel

1. Loosen screws on back of handle pad assembly and rear pad with 3mm Allen wrench.
2. Remove handle pad assembly and rear pad. Do not remove the screw from the handle pad assembly (see Figure 5).

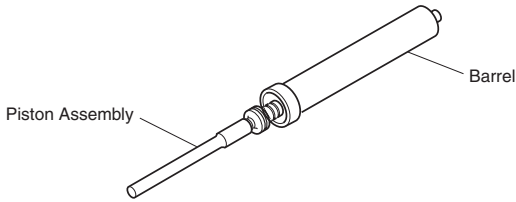
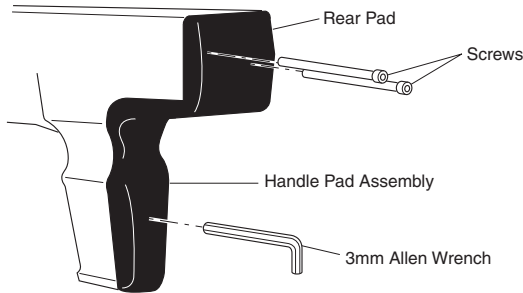

Figure 5 - Removing Handle Pad Assembly and Rear Pad

C. REMOVING ROCKER ARM ASSEMBLY

1. Rocker arm assembly is located in housing. Pull rocker arm assembly out of housing (see Figure 6).
2. Pull rocker arm spring away from handle pad assembly to remove (see Figure 7)

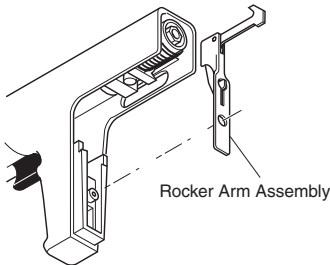

Figure 6 - Removing Rocker Arm Assembly from Housing

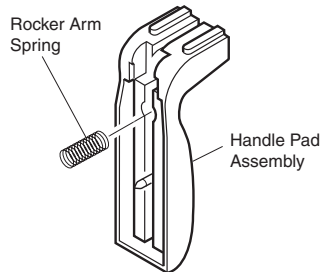

Figure 7 - Removing Rocker Arm Spring from Handle Pad

DISASSEMBLY

D. REMOVING FIRING PIN

1. Remove two springs from outer liner assembly (see Figure 8).
2. Push in sear and pull out firing pin guide (see Figure 8). Line up sear with end of slot. Remove spring and sear. Remove firing pin assembly. Remove push pin (see Figure 9).

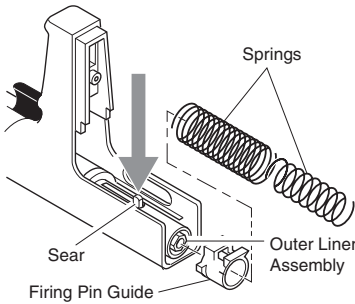

Figure 8 - Removing Springs and Pushing in Sear to Remove Firing Pin Guide

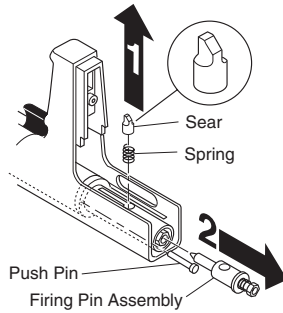

Figure 9 - Removing Sear, Spring, Firing Pin Assembly, and Push Pin

E. REMOVING TRIGGER ASSEMBLY

1. Remove trigger pin from housing with hammer and punch (see Figure 10).
2. Remove trigger assembly from rear of housing.

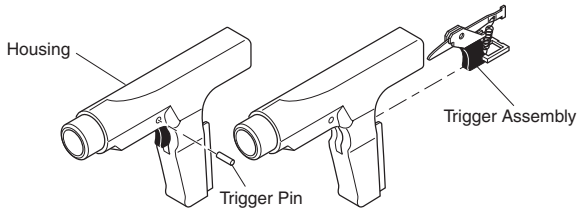

Figure 10 - Removing Trigger Pin and Trigger Assembly

F. REMOVING OUTER LINER ASSEMBLY FROM HOUSING

1. Grasp outer liner assembly and remove from housing.
2. Remove spring and ball bearing located at rear of liner.

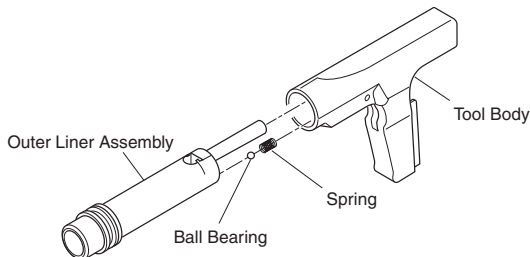

Figure 11 - Removing Outer Liner Assembly from Housing

Reverse the disassembly instructions to reassemble the tool.

WARNING

POWDER

ACTUATED

TOOL

IN USE

WARRANTY

ALL WARRANTIES OF THE PRODUCTS DESCRIBED HEREIN, EXPRESSED OR IMPLIED, INCLUDING THE WARRANTY OF MERCHANTABILITY AND FITNESS FOR PARTICULAR PURPOSES ARE SPECIFICALLY EXCLUDED, EXCEPT FOR THE FOLLOWING: ITW BRANDS WILL REPAIR OR REPLACE AT ITS SOLE OPTION ANY TOOL PART OR FASTENER WHICH WITHIN 1 YEAR AFTER SALE BY ITW BRANDS IS FOUND BY ITW BRANDS TO BE DEFECTIVE IN MATERIAL OR WORKMANSHIP, NORMAL WEAR AND TEAR EXCLUDED. THIS IS THE SOLE WARRANTY OF ITW BRANDS AND THE SOLE REMEDY AVAILABLE TO THE BUYER.

**For warranty returns contact: ITW Brands, Attn: QA Department,
1575 Hunter Road, Suite A, Hanover Park, IL 60133; Phone: (877)
489-2726.**

**FOR TECHNICAL ASSISTANCE CALL:
877-489-2726**

**THE MODEL DF-27 TOOL COMPLIES WITH OSHA REQUIREMENTS
AND WITH ANSI A10.3 SPECIFICATIONS**



**ITW Brands
Schaumburg, IL 60173
877-489-2726**

AN ILLINOIS TOOL WORKS COMPANY
© ILLINOIS TOOL WORKS 2009

OPERATOR'S EXAMINATION

After studying and understanding the material in this tool manual, answer the following questions. Complete the information on the other side of this page. Enclose a copy of your sales receipt and send to the address on the back of this manual to activate your tool warranty and receive your tool license.

1. Safety goggles and hearing protection must always be worn by the operator and any necessary bystanders when using the tool.
 True False
2. The strongest power level should be tried first when making the first fastening.
 True False
3. Never attempt to fire the tool until the muzzle end is compressed against the work surface and you are ready to make a fastening.
 True False
4. Sheet rock, drywall board, wood, fiberglass, ceramic tile, brick and thin sheet metal are examples of materials not to be fastened into.
 True False
5. A powder actuated tool can be safely used in an explosive or flammable atmosphere.
 True False
6. Malfunctioning tools can be used and do not have to be removed from service immediately.
 True False
7. When operating a powder actuated tool, your hand should never be placed in front of the tool muzzle.
 True False
8. Poured concrete and structural steel are suitable materials for fastening into.
 True False
9. To determine the suitability of a base material, use a fastener as a center punch as follows:
A) If the fastener is blunted, do not fasten; the material is too hard. True False
B) If the fastener penetrates easily, do not fasten; the material is too soft. True False
C) If the material cracks or shatters, do not fasten; the material is too brittle. True False
10. In concrete, a fastener should be driven no closer to a free edge than 3".
 True False
11. When fastening into concrete, the base material should be greater than the shank penetration by at least 3 times.
 True False
12. Do not drive fasteners into steel that is thinner than 3/16".
 True False
13. Powder actuated tools, fasteners and loads, must always be kept in a secure, locked area when not in use to avoid access by unauthorized persons.
 True False
14. When considering the safety of a particular application, the operator must think about all of the following: a) the powder load power level, b) the operator's safety, c) the safety of bystanders and fellow workers, d) the base or receiving material.
 True False
15. It is not necessary to read the Operator's Manual prior to operating the DF-27 low velocity powder actuated tool.
 True False
16. The best way to check the receiving material is to set several fasteners using the most powerful load.
 True False
17. Piston overdrive is caused by overpowering of the tool or by discharging the tool against a soft surface.
 True False
18. One should never attempt to pry a stuck load out of a tool.
 True False
19. Placing a hand over the muzzle end of a loaded tool can result in serious injury from piston overdrive or an escaping fastener if the tool is discharged accidentally.
 True False

Signed _____

Date _____

OPERATOR'S EXAMINATION

LICENSE AND WARRANTY ACTIVATION _____

The DF-27 Tool is warranted for 1 Year after sale by ITW Brands.

I certify that I have read and understand the DF-27 Tool Operator's Instruction and Training Manual and have taken the Operator's Exam on the reverse side.

(Please Print Clearly)

The serial number on my tool is: _____

Please send my tool license to:

Name _____

Address _____

City _____ State _____ Zip _____

Phone _____

Email _____

Yes. I would like to receive product updates and information from Duo-Fast.

RETURN TO:

In USA

ITW Brands
ATTN: License Coordinator
955 National Parkway, Suite 95500
Schaumburg, IL 60173

LICENSE AND WARRANTY ACTIVATION _____